

WRU01001 – WIRELESS ROOM UNIT FOR MEASURING TEMPERATURE, HUMIDITY

W06.01en



DESCRIPTION AND APPLICATION

WRU01001 is a wireless, battery powered HMI unit. The device features temperature and humidity sensors, the values of which can be displayed to user on a large LCD display. It features a native modbus map that grants seamless integration into the DDC/SCADA system. The communication is based on the encrypted Midam KFP protocol, which allows to update the device firmware on a wireless basis.

Application

- HVAC control
- measurement of temperature and humidity
- display of status values
- wireless integration into SCADA control systems

FUNCTION

The wireless room unit measures temperature and relative humidity. It allows to set the desired temperature setpoint and operating modes using the rotating knob. The values are transmitted through the 868 MHz unlicensed band to the WCOM51 gateway. There is also an option without rotating knob and display available. The room unit features a native modbus map with the direct read and write functionality. The modbus map is available in a separate document. All settings and configuration are also stored in a modbus register, directly in the device. It is necessary to pair the device before first use and to enter the encryption password.

SCADA SYSTEM INTEGRATION

The controller can be integrated into DDC or SCADA systems directly via the WCOM51 wireless gateway.

PAIRING

To pair your own sensors with the WCOM51 GSM gateway, the freely downloadable KFP-Lite software is available, which communicates with the gateway using the WUSB01 wireless USB configurator. Both devices must be powered and placed in close proximity to each other. Using the search function in the software interface, you can view a list of all available devices in range and assign or modify parameters based on the wireless identification code for each individual device.

Using KFP-Lite, it is possible to change the communication frequency (default value 868.95 MHz).

BATTERY CHANGE

Remove the base lid of the controller by gently pressing it on the sides. Remove old batteries from the bracket and place new batteries. Observe the battery type and polarity. Always replace both batteries with fresh ones. Then put both parts together and close the controller again.



SPECIFICATIONS

Wireless room unit	WRU01001
Power supply	4,5V, 3× main alkaline battery 1,5V, type AA
Consumption	idle: <5 uA, avg. typical: 10 uA, max.: 25 mA
Battery life	up to 3 years – batteries are not supplied with the device
Communication	868.950 MHz, 100 kbps, WMBUS T1, KFP 868.300 MHz, 32 kbps, WMBUS S1, KFP 868.100 MHz, 100 kbps, KFP 869.525 MHz, 100 kbps, WMBUS C, KFP 868.300 MHz, 38 kbps, KFP
Protocol	WMBUS (EN 13757-4), KFP (dual stack)
Encryption	AES 128 PCBC, EN 13757-4
RF power	+10 to - 20 dBm, step 5 dB
Antenna	Integrated
Communication range	100 m in free space, 30 m in buildings
Mechanical and dimensions	90×115×30 mm enclosure ABS, IP 20 in accordance with EN 60529, as amended 2 × DIP switch (INIT mode, USR mode)
Temperature measurement range	-20 to 55 °C, ± 0,5 °C
Humidity measuring range	10 to 90 % rH, ±3% rH
Temperature setpoint	configurable, ± 10 to ± 1 K
Display	reflexive segmented LCD 60×60 mm
Ambient conditions	-5 to 45 °C, 5 % to 95 % rH (EN 60721-3-3 class 3K5)

WIRING DIAGRAM

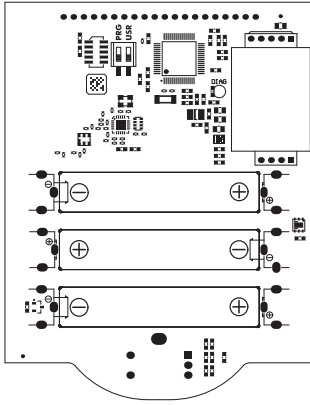

- PRG** Default frequency, power and password is used in ON position
- USR** Not used
- DIAG** LED indication, sending data

DISPLAY

The large LCD shows the current temperature, humidity and fancoil controller status using segment symbols, standard symbols for day and night mode, time programs and activated output. At the top of the display there are symbols indicating the day of the week. The bell symbol indicates a communication error, while the side wrench symbol indicates weak batteries.

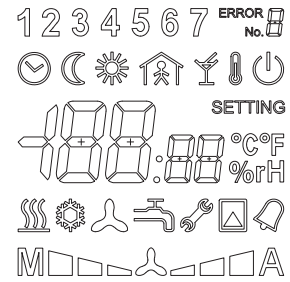

DIMENSIONAL DRAFT

