

TR 155A
TR 155B

Temperature sensor

Z074.2a

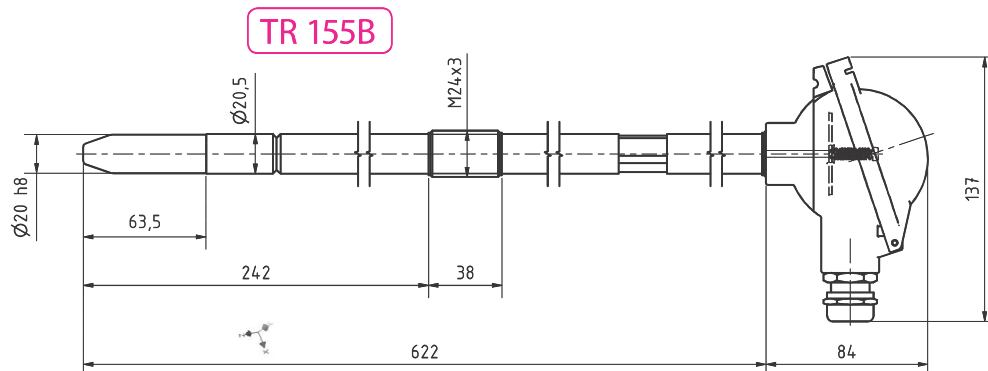
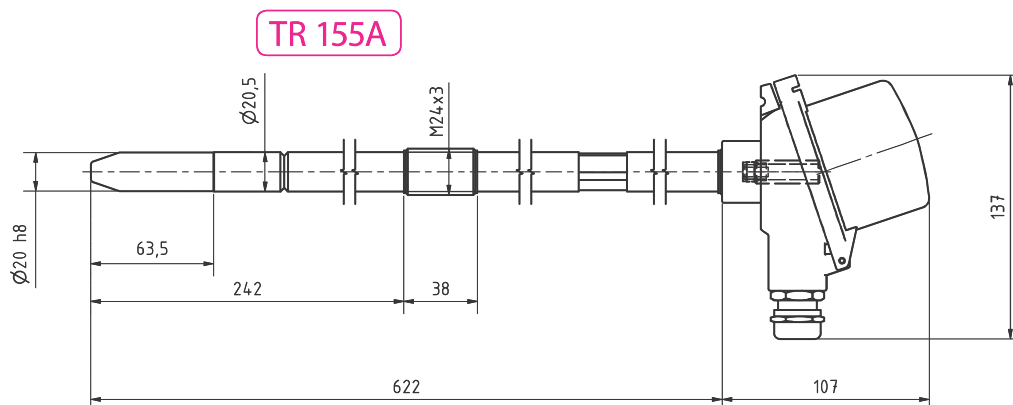

DESCRIPTION AND APPLICATION ↓

The **TR 155A** and **TR 155B** temperature sensors are designed taking into account specific needs of temperature measurement of the rubber mixtures processing in the rubber industry. The temperature sensor of variant A is equipped with the LEMO connector and can be completed by a metal connection head. The temperature sensor of variant B is equipped with a ceramic terminal block placed in a connection head.

The temperature sensors are highly resistant to abrasion influence of rubber mixtures and to vibrations. The sensors can be also used to measure temperature of plastic and bulk materials. The cases of the temperature sensors are made of stainless steel. And with its design, faster time response is achieved compared to sensors installed into a thermowell.

DECLARATION, CERTIFICATION, CALIBRATION ↓

- Manufacturer provides **EU Declaration of Conformity**.
- Calibration** – The final metrological inspection – comparison with standards or working instruments – is carried out for all the products. Continuity of the standards and working measuring instruments is ensured within the meaning of the Section 5 of Act no.505/1990 on metrology. The manufacturer offers a possibility to supply the sensors calibrated in SENSIT s.r.o.'s laboratory (according to requirements of the EN ISO/IEC 17025 standard, as amended) or in an Accredited laboratory.

SPECIFICATIONS ↓

Sensor type	TR 155A	TR 155B
Type of sensing element	Pt 100, TCK, TCI, other as requested	
Recommended measuring current	≤ 3 mA for Pt 100/3850 measuring element	
Measuring range	-30 °C to 200 °C	
Connection	4wire	
Case material	stainless steel, measuring tip made of hardening steel	
Time response Immersion depth 100 mm	according to the EN 60751 standard: $\tau_{0,5} < 6\text{ s}$, $\tau_{0,9} < 14\text{ s}$ Continental method*: $\tau_{0,5} < 17\text{ s}$, $\tau_{0,9} < 80\text{ s}$	
Minimum immersion depth	40 mm	
Connector	LEMO PCA.1S.304.CLLC	—
Terminal block	—	YES
Connection head	DANW4-M2A-4x-NS- Cal as accessory	NAA2-M2X-6x-NS-Cal - fixed component of the sensor
Insulation resistance	> 200 MΩ at 500 V _{DC} , 25°C ± 3°C, humidity < 80%	
Weight	1.3 kg	

* from 0 °C (crushed ice) to 180 °C (flowing silicon oil 0.4 ms⁻¹)

ACCESSORIES ↓

- DANW4-M2A-4x-NS-Cal connection head for the variant A
- Cable connector counterpart for the variant A - LEMO FFA.1S.304.CLAC62
- Connection cable with the LEMO FFA.1S.304.CLAC62 connector for the variant A

WIRING DIAGRAM ↓

- Pt 100 – 4wire connection

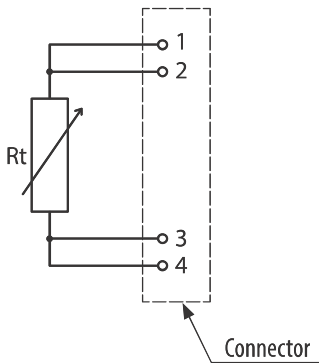

- Thermocouple type K or J

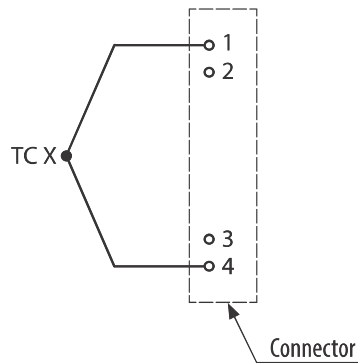

OPTIONAL ACCESSORIES FOR VERSION A ↓

- Connection head DANW4-M2A-4x-NS-Cal

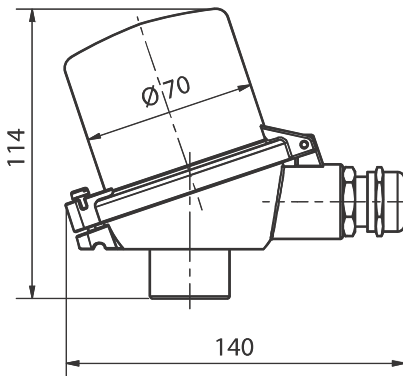

- Connector LEMO FFA.1S.304.CLAC62 – for cable $\varnothing 5.3-6.1$ mm



- Connection cable with the LEMO FFA.1S.304.CLAC62



www.sensit-rubberplastic.cz

SENSIT s.r.o., Skolní 2610, 756 61 Rožnov pod Radhoštěm, Czech Republic
T +420 571 625 571 F +420 571 625 572 E obchod@sensit.cz



Z074.2a | 04/20

replace Z074.1a

