

TR 153C

Temperature sensor

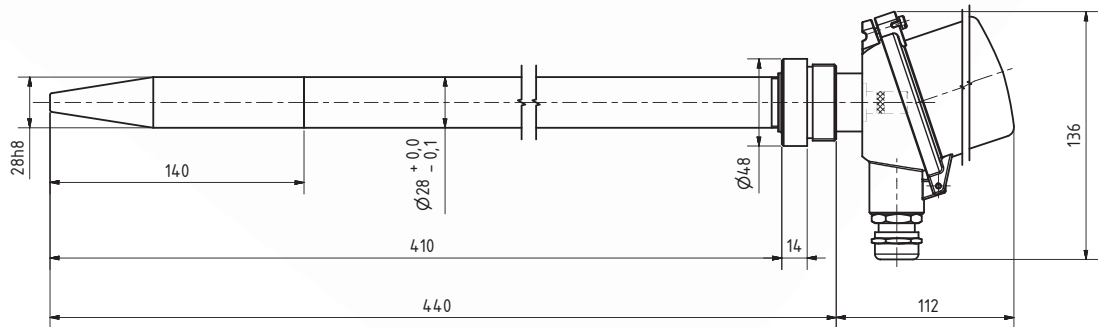

Z034.4a

TR 153C

DESCRIPTION AND APPLICATION ↓

The **TR 153C** temperature sensor is designed taking into account specific needs of temperature measurement of the rubber mixtures processing in the rubber industry. The temperature sensor is equipped with the LEMO connector and can be completed by a metal connection head.

The temperature sensor is highly resistant to abrasion influence of rubber mixtures and to vibrations. The sensor can be also used to measure temperature of plastic and bulk materials. The case of the temperature sensor is made of stainless steel. And with its design, faster time response is achieved compared to sensors installed into a thermowell.

DECLARATION, CERTIFICATION, CALIBRATION ↓

- Manufacturer provides **EU Declaration of Conformity**.
- **Calibration** – The final metrological inspection – comparison with standards or working instruments – is carried out for all the products. Continuity of the standards and working measuring instruments is ensured within the meaning of the Section 5 of Act no.505/1990 on metrology. The manufacturer offers a possibility to supply the sensors calibrated in SENSIT s.r.o.'s laboratory (according to requirements of the EN ISO/IEC 17025 standard, as amended) or in an Accredited laboratory.

SPECIFICATIONS ↓

Sensor type	TR 153C
Type of sensing element	Pt 100, TCK, TCI, other as requested
Recommended measuring current	≤ 3 mA for Pt 100/3850 measuring element
Measuring range	-30 °C to 200 °C
Connection	4wire
Case material	stainless steel, measuring tip made of hardening steel
Time response Immersion depth 100 mm	according to the EN 60751 standard: $\tau_{0,5} < 6$ s, $\tau_{0,9} < 14$ s Continental method*: $\tau_{0,5} < 17$ s, $\tau_{0,9} < 80$ s
Minimum immersion depth	40 mm
Connector	LEMO PCA.15.304.CLLC
Connection head	DANW4-M2A-4x-NS-Cal as accessory, NAA2-M2X-6x-NS-Cal - fixed component of the sensor
Insulation resistance	> 200 M Ω at 500 V _{DC} , 25°C ± 3°C, humidity < 80%
Weight	1.8 kg

* from 0 °C (crushed ice) to 180 °C (flowing silicon oil 0.4 ms⁻¹)

ACCESSORIES ↓

- DANW4-M2A-4x-NS-CaL connection head
- Cable connector counterpart - LEMO FFA.1S.304.CLAC62
- Connection cable with the LEMO FFA.1S.304.CLAC62 connector

WIRING DIAGRAM ↓

- Pt 100 – 4wire connection

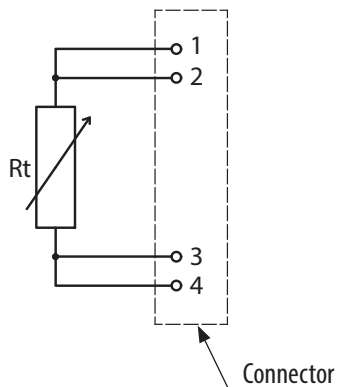

- Thermocouple type K or J

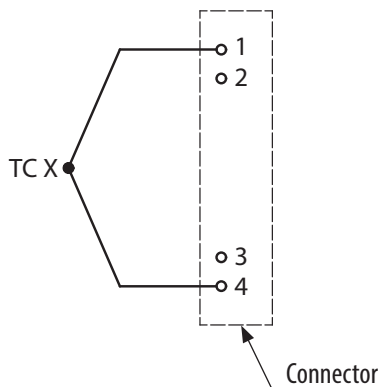

OPTIONAL ACCESSORIES ↓

- Connection head DANW4-M2A-4x-NS-CaL

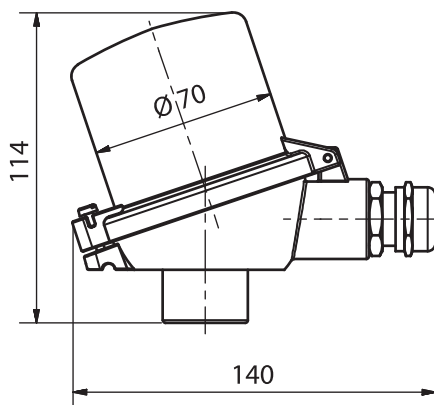

- Connector LEMO FFA.1S.304.CLAC62 – for cable $\text{Ø} 5.3\text{--}6.1$ mm



- Connection cable with the LEMO FFA.1S.304.CLAC62



www.sensit-rubberplastic.cz

SENSIT s.r.o., Skolní 2610, 756 61 Roznov pod Radhostem, Czech Republic
T +420 571 625 571 F +420 571 625 572 E obchod@sensit.cz



Z034.4a | 04/20

replace Z034.3a

