

TEMPERATURE SENSORS UP TO 400 °C WITH PROGRAMMABLE CONVERTER 4–20 mA

115.08en

DESCRIPTION AND APPLICATION

These resistance-type sensors are intended for contact measurements of temperatures up to 400 °C. Temperature sensors, in combination with a central holder or thermowell, can be used to measure the temperature in various applications of an industrial environment. The sensor variant with welded thread is ideal for direct measuring of mediums in ducts. The standard operating temperature range is -50 to 400 °C. The sensors can be utilised for any control systems that are compatible with output signal 4–20 mA. The sensors are designed to be operated in a chemically non-aggressive environment.



ACCESSORIES

- metal central holder K 120
- stainless steel thermowell JPTS 41
- screw with collet or cutting rings – if different lengths of stem immersion of the temperature sensor are set

DECLARATION, CERTIFICATES, CALIBRATION

Manufacturer provides **EU Declaration of Conformity**.

Calibration – The final metrological inspection – comparison with standards or working instruments – is carried out for all the products. Continuity of the standards and working measuring instruments is ensured within the meaning of the Section 5 of Act no.505/1990 on metrology. The manufacturer offers a possibility to supply the sensors calibrated in SENSIT s.r.o.'s laboratory (according to requirements of the EN ISO/IEC 17025 standard, as amended) or in an Accredited laboratory.

MAXIMUM FLOW SPEED OF THE MEASURED MEDIUM - AIR AND WATER VAPOUR / WATER [m.s⁻¹]

Length of the thermowell/stem	> 60 to 100 mm	> 100 to 160 mm	> 160 to 220 mm	> 220 to 400 mm
Values for the versions with thread	15 / 1.5	8.0 / 1.0	2.5 / 0.6	0.6 / 0.3

SPECIFICATIONS

Sensor type with smooth stem	PTS 81
Sensor type with welded-on thread	PTS 91
Type of sensing element	Pt 1000/3850
Output signal	4 to 20 mA
Maximum measuring range	-50 to 400 °C
Adjustable measuring range	optional, minimum interval 10 °C
Accuracy of sensing element	class B in accordance with EN 60751
Accuracy of converter	temperature error < 0.05 °C error of setting < 0.12 °C error of linearity < 0.05 % from the set range, minimum 0.16 °C influence of supply voltage < 0.005 %/ V from the range
Current limitation	sensing element short < 3.2 mA sensing element break > 22.7 mA
Lead-in connection	1.5 to 2.5 mm ²
Ingress protection	IP 54 in accordance with EN 60529, as amended
Material of stem	stainless steel DIN 1.4301
Standard length of the stem L1	50, 100, 160, 220, 280, 400 mm
Nominal pressure of the stem	PN 63 (with a thread)
Method of programming	AY – USB adapter *
Thread types by PTS 91	G ½"; M 20 x 1.5; M 27 x 2
Insulation resistance	> 200 MΩ at 500 V _{DC} , 25 °C ± 3 °C; humidity < 85 %
Material of connection head	aluminium alloy, LIMATHERM B
Operating conditions	ambient temperature: -25 to 70 °C relative humidity: max. 100 % (at the ambient temperature 25 °C) atmospheric pressure: 70 to 107 kPa
Weight approximately	0.25 kg

*programming software is free

WIRING DIAGRAM

With a converter 4 to 20 mA

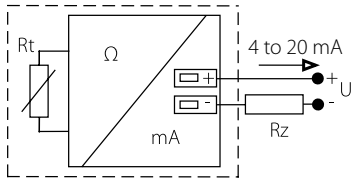

DIMENSIONAL DRAFT

PTS 81

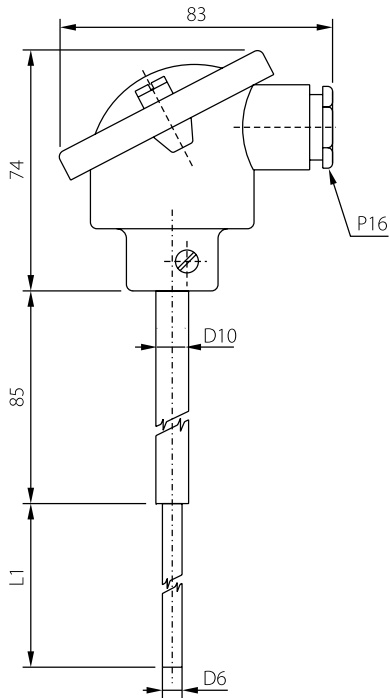

PTS 91

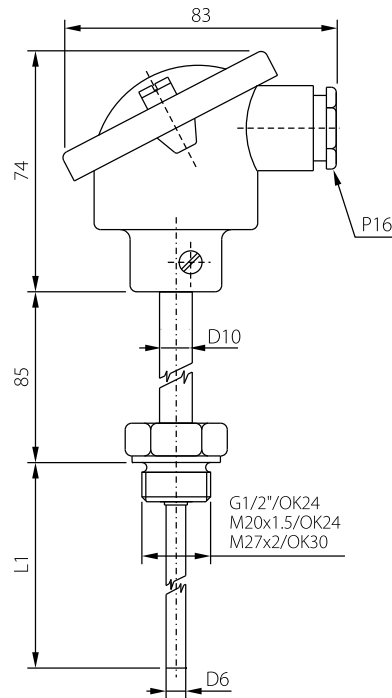

Accessories

(for the sensors PTS 81, PTS 91 only)

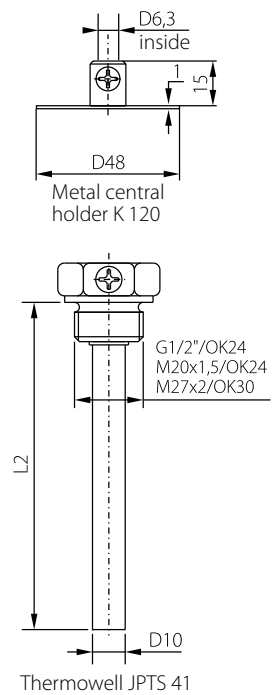

MODIFICATION AND CUSTOMIZATION

- variable stem design – L1 length, materials, diameters, option of thread design
- thermowell thread type options

