

TEMPERATURE SENSORS UP TO 400 °C WITH IP 68

029.07en

DESCRIPTION AND APPLICATION

These resistance-type sensors are intended for contact measurements of temperatures up to 400 °C. Temperature sensors, in combination with a central holder or thermowell, can be used to measure the temperature in various applications of an industrial environment. The sensor variant with welded thread is ideal for direct measuring of mediums in ducts. The sensors meet the level of protection IP 68 in accordance with EN 60529, as amended. The standard operating temperature range is -50 to 400 °C. The sensors can be utilised for any control systems that are compatible with sensing element output signals or output signals quoted in the table of sensing element types. The sensors are designed to be operated in a chemically non-aggressive environment.

ACCESSORIES

- metal central holder K 120
- stainless steel thermowell JPTS 41
- screw with collet or cutting rings – if different lengths of stem immersion of the temperature sensor are set

DECLARATION, CERTIFICATES, CALIBRATION

Manufacturer provides **EU Declaration of Conformity**.

Calibration – The final metrological inspection – comparison with standards or working instruments – is carried out for all the products. Continuity of the standards and working measuring instruments is ensured within the meaning of the Section 5 of Act no.505/1990 on metrology. The manufacturer offers a possibility to supply the sensors calibrated in SENSIT s.r.o.'s laboratory (according to requirements of the EN ISO/IEC 17025 standard, as amended) or in an Accredited laboratory.

MAXIMUM FLOW SPEED OF THE MEASURED MEDIUM - AIR AND WATER VAPOUR / WATER [m.s⁻¹]

Length of the thermowell/stem	> 60 to 100 mm	> 100 to 160 mm	> 160 to 220 mm	> 220 to 400 mm
Values for the versions with thread	15 / 1.5	8.0 / 1.0	2.5 / 0.6	0.6 / 0.3

SPECIFICATIONS

Sensor type with smooth stem	PTS 441	PTS 443	PTS 445
Sensor type with welded-on thread	PTS 461	PTS 463	PTS 465
Type of sensing element	Pt 100	Pt 500	Pt 1000
Measuring range B class	-50 to 400 °C		
Maximum measuring DC current	3 mA	1.5 mA	1 mA

Sensor type with smooth stem	PTS 451	Note
Sensor type with welded-on thread	PTS 471	
Type of sensing element	Pt 1000/3850	
Output signal	4 to 20 mA	
Measuring ranges	-50 to 50 °C 0 to 100 °C 0 to 150 °C 0 to 200 °C 0 to 400 °C	ambient temperature around the connection head -30 to 70 °C
Power supply (U)	11 to 30 V _{DC}	recommended value 24 V _{DC}
Load resistance	150 Ω for power supply 12 V 700 Ω for power supply 24 V	
Output signal - sensing element break	> 25 mA	
Output signal - sensing element short circuit	< 3.5 mA	



OTHER PARAMETERS

Accuracy class	B class according to EN 60751, $t = \pm (0.3 + 0.005 t)$ in °C A class according to EN 60751, $t = \pm (0.15 + 0.002 t)$ in °C
Measuring error	< 0.6 % of the measuring range, minimum 0.5 °C
Sensor connection	according to the wiring diagram
Standard length of the stem L1	50, 100, 160, 220, 280, 400 mm
Nominal pressure of the stem	PN 63 (with a thread)
Time response	$\tau_{0.5} < 9$ s (in flowing water at 0.4 m.s ⁻¹)
Recommended wire cross section	0.35 to 1.5 mm ²
Thead types for PTS 61, PTS 63, PTS 65, PTS 71	G 1/2"; M 20 x 1.5; M 27 x 2
Insulation resistance	> 200 MΩ at 500 V _{DC} , 25° ± 3 °C; humidity < 85 %
Ingress protection	IP 54 in accordance with to EN 60529, as amended
Material of the stem	stainless steel DIN 1.4301
Material of the connection head	aluminium alloy, LIMATHERM B
Operating conditions	ambient temperature: -30 to 100 °C; -30 to 70 °C with a converter relative humidity: max. 100 % (at the ambient temperature 25 °C) atmospheric pressure: 70 to 107 kPa
Weight approximately	0.25 kg

WIRING DIAGRAM

With a resistance output

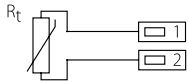

With a converter 4 to 20 mA

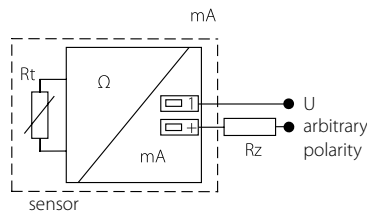

DIMENSIONAL DRAFT

PTS 441, PTS 443,
PTS 445, PTS 451

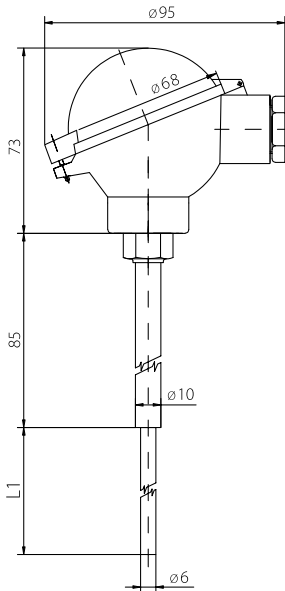

PTS 461, PTS 463,
PTS 465, PTS 471

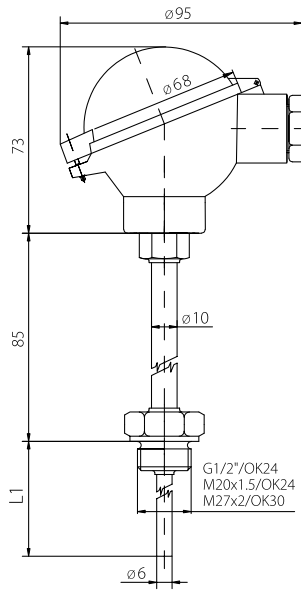

Accessories
(for the sensors PTS 441,
PTS 443, PTS 445, PTS 451 only)

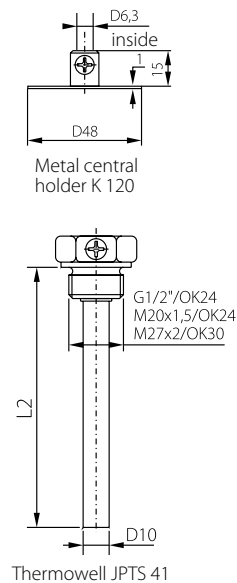

MODIFICATION AND CUSTOMIZATION

- option of encasing two sensing element
- accuracy class A for the range -50 to 250 °C
- option of three- or four-wire connection
- variable stem design – L1 length, materials, diameters, option of thread design
- thermowell thread type options

