

DESCRIPTION AND APPLICATION

The sensors of the serie SD 11x are intelligent microprocessor-controlled temperature sensors that are a result of cooperation with the company MIKROKLIMA s.r.o. They consist of a sensing element encased in a stainless steel (class EN X5CrNi18-10, DIN 1.4301) stem and of printed circuit boards encased in a plastic connection head provided with a cable outlet ending. The sensors meet the IP65 ingress protection requirements according to the EN 60 529 standard. The measured temperature range is -30 to +70°C. They are available in three basic variants:

- SD 110** – with a simple ASCII communication protocol corresponds with ADAM 4000 modules by ADVANTECH company. Thus, standard drivers for ADAM modules can be used in various control programmes. For easier operation, the green LED indicates if power supply is on and the red LED indicates that the module is communicating. The SD 1x0 module is provided by the INIT shorting jumper on its printed circuit board. If it is shorted when power is switched on, the module communicates on 00 address with 9600 Bd transfer speed without checksum.
- SD 111** – the command structure corresponds with the ARION communication protocol, which is used among control systems by Amit company.
- SD 112** – the command structure corresponds with the ModBus communication protocol.



SD 11x outdoor sensors are intended for temperature measurement in industrial areas or outdoors. A metal holder for sensor installation onto vertical surfaces is among available accessories. The sensors communicate by means of RS 485 bus and only the bus can control the sensors.

Communication inputs are protected to overvoltage. In case the module is placed as terminal on the line, a terminating resistor can be attached to the wiring by shorting the contacts (the switch SW placed next to terminals for communication lines connection).

All settings are stored in EEPROM memory. The electronic module is equipped with the WATCHDOG circuit, which safeguards proper program functioning in the microprocessor.

SPECIFICATIONS

Sensor type	SD 110	SD 111	SD 112
Power supply	10 to 35 V DC (unstabilized) 14 to 24 V AC		
Power consumption	300 mW		
Measuring range	-30 to 70 °C		
Standard stem length	25 mm		
Communication properties	communication via RS 485, maximum segment length is 1200 m, asynchronous transfer		
	transfer speeds 1200, 2400, 4800, 9600, 19200 Bd	transfer speeds 9600, 19200, 38400, 57600 Bd – DIP switch	preset transfer speed 9600 Bd optional transfer speeds 1200, 2400, 4800, 19200, 57600, 115200 Bd – DIP switch
	256 modules / 1 serial port	63 modules / 1 serial port	247 modules / 1 serial port
	protocol consistent with ADAM modules	protocol ARION	protocol ModBus 1 stop bit, without parity
Accuracy of electronics	0,05 %		
Accuracy of sensing element	± 0,5 °C		
Resolution	0,03125 °C		
Working conditions	ambient temperature: -30 to 70 °C		
	relative humidity: max. 85 % (at the ambient temperature 25 °C)		
	atmospheric pressure: 87 to 107 kPa		
Mass	0,2 kg		

WIRING DIAGRAM

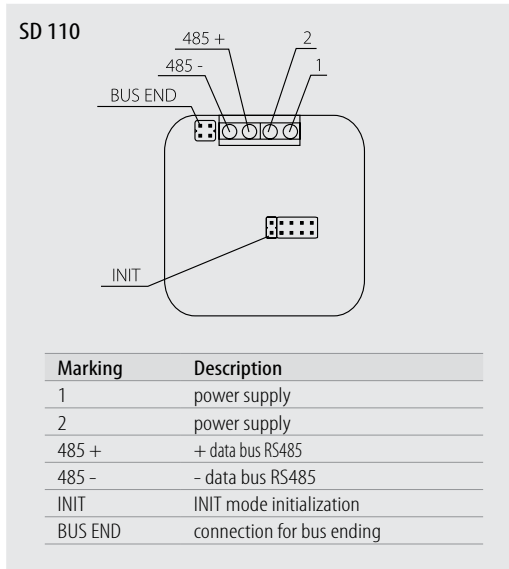

DIMENSIONAL DRAFT

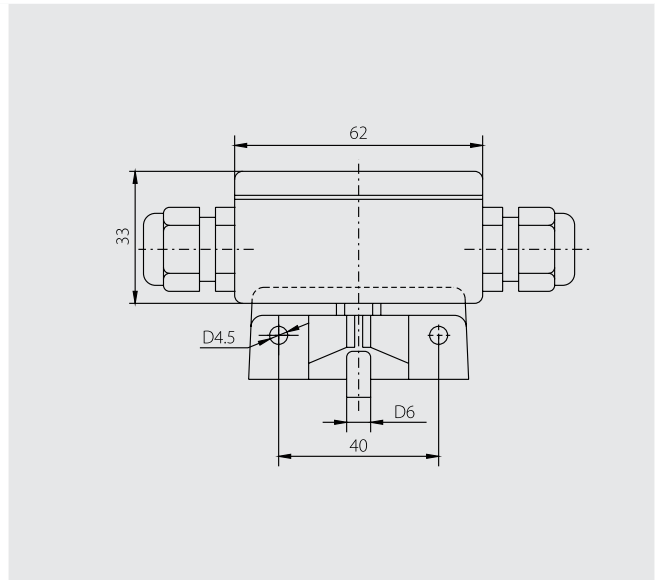

SENSOR INSTALLATION AND MAINTENANCE

Prior to connecting the supply lead-in cable, unscrew the lid of the plastic connection head. Push the lead-in cable through the loosened grommet and connect it to the terminals according to the wiring diagram. Recommended wire cross-section is 0.35 - 1.5 mm², the outer diameter of the circular cross-section cable can range between 4 and 8 mm. In case the lead-in cable is laid in the vicinity of high voltage conductors or those supplying equipment creating disturbing electromagnetic field (e.g. inductive load equipment), a shielded cable should be used. To insure the ingress protection value of IP 65 the grommet has to be tightened and the lid has to be screwed on after connecting the lead-in cable. Holes for the plastic holder installation should be drilled according to the dimensional draft, where their diameters and distance from center to center are specified. After installing and connecting the sensor to the appropriate evaluating electrical equipment the sensor is ready to use. The sensor does not require any special servicing or maintenance. The device can be operated in any working position but the grommet must not be directed upwards.

CUSTOMER SPECIFIC MODIFICATIONS

REGARDING TO SENSORS MANUFACTURED IN A STANDARD VERSION THE FOLLOWING PARAMETERS CAN BE MODIFIED:
 – stainless steel material modification, for example DIN 1.4571

HOW TO ORDER

Temperature sensors for outdoor usage	1	5	1	C	C	D	D	0	0	0	0	0	0
Active digital sensor				0	D								
with protocol ADAM						0	0						
with protocol ARION						0	1						
with protocol ModBus						0	2						

WHEN ORDERING GOODS, THE FOLLOWING DATA ARE REQUIRED:

Required data	Example
Product type	SD 110
Protocol	ADAM

DELIVERY

The sensors are packed in boxes by 1 piece.
 Each delivery contains, if not agreed with the customer otherwise: a plastic side holder
 In addition, the following items can be provided together with the product: – a calibration sheet
 – the EU Declaration of Conformity.