

## DESCRIPTION AND APPLICATION

These resistance-type sensors are intended for contact measurements of temperatures up to 400 °C. They consist of a metal measuring stem and a metal connection head, in which a terminal board is encased. These sensors are produced in two versions: with a smooth stem, and with a stem provided with a welded-on screwed joint. The sensor stem is made of the stainless steel EN X5CrNi18-10 (DIN 1.4301), the connection head is made of aluminium alloy. The basic lengths of the measuring stems are 50, 100, 160, 220, 280 and 400 mm. The metal connection head is provided with a cable outlet ending. All these sensor types meet the IP 54 ingress protection requirements according to the EN 60 529 standard.

By combination of the sensor and a stainless steel central holder or a thermowell, which are both available optionally, it is possible to use the sensors for temperature measurements in various applications of the industrial sphere. The sensors can be utilised for any control system that is compatible with sensing element output signals or output signals quoted in the sensing element specification table.

The standard temperature range in which the sensors are allowed to be utilised is -50 to +400 °C.

The sensors are designed to be operated in a chemically non-aggressive environment.



### MAXIMUM STREAM VELOCITY OF THE MEASURED MEDIUM - AIR AND WATER VAPOUR / WATER [m.s<sup>-1</sup>]

Length of the thermowell/stem	> 60 to 100 mm	> 100 to 160 mm	> 160 to 220 mm	> 220 to 400 mm
Values for the versions with screw joint	15 / 1,5	8,0 / 1,0	2,5 / 0,6	0,6 / 0,3

## SPECIFICATIONS

### BASIC DATA

Sensor type with smooth stem	PTS 41	PTS 43	PTS 45
Sensor type with welded-on screwed joint	PTS 61	PTS 63	PTS 65
Type of sensing element	Pt 100	Pt 500	Pt 1000
Measuring range B class	-50 to 400 °C		
Measuring range A class	-50 to 300 °C		
Maximum measuring DC current	3 mA	1,5 mA	1 mA

Sensor type with smooth stem	PTS 51	Note
Sensor type with welded-on screwed joint	PTS 71	
Type of sensing element	Pt 1000/3850	
Output signal	4 to 20 mA	
Measuring ranges	-50 to 50 °C	Connection head ambient temperature -30 to 80 °C
	0 to 100 °C	
	0 to 150 °C	
	0 to 200 °C	
	0 to 400 °C	
Power supply (U <sub>NAP</sub> )	11 to 30 V DC	Recommended value 24 V DC
Maximum voltage ripple U <sub>NAP</sub>	0,5 %	
Load resistance	50(U <sub>NAP</sub> -10) Ω	
Output signal - sensing element break	> 25 mA	
Output signal - sensing element short	< 3,5 mA	

## OTHER PARAMETERS:

Accuracy class	B class according to IEC 751, $\Delta t = \pm (0,3 + 0,005 t )$ in °C A class according to IEC 751, $\Delta t = \pm (0,15 + 0,002 t )$ in °C
Measuring error	< 0,6 % of the measuring range, minimum 0,5 °C
Sensor connection	according to the wiring diagram
Standard length of the stem L1	50, 100, 160, 220, 280, 400 mm
Nominal pressure of the stem	PN 63 (with a screw joint)
Time response	$t_{0,5} < 9$ s (in streaming water at 0,4 m.s <sup>-1</sup> )
Recommended wire cross section	0,35 to 1,5 mm <sup>2</sup>
Thead types for PTS61, PTS63, PTS65, PTS71	G 1/2"; M 20 x 1,5; M 27 x 2
Insulation resistance	> 200 MΩ at 500 V DC, 25° ± 3 °C; humidity < 85 %
Ingress protection	IP 54 according to EN 60 529
Material of the stem	stainless steel EN X5CrNi18-10 (DIN 1.4301)
Material of the connection head	aluminium LIMATHERM B
Grommet type	P 16
Operating conditions	ambient temperature: -30 to 100 °C; -30 to 80 °C with a converter relative humidity: max. 85 % (at the ambient temperature 25 °C) atmospheric pressure: 87 to 107 kPa
Mass	approximately 0,25 kg

## WIRING DIAGRAM

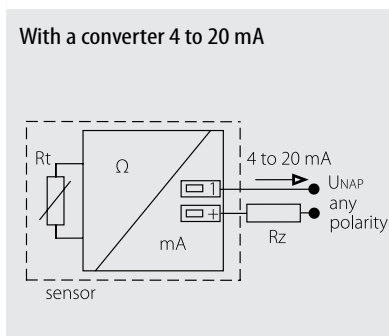
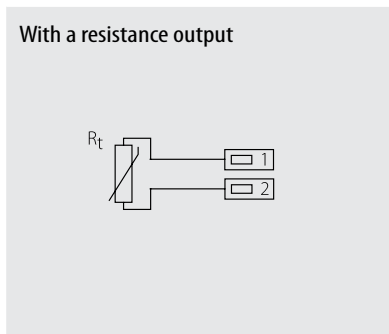

## DIMENSIONAL DRAFT

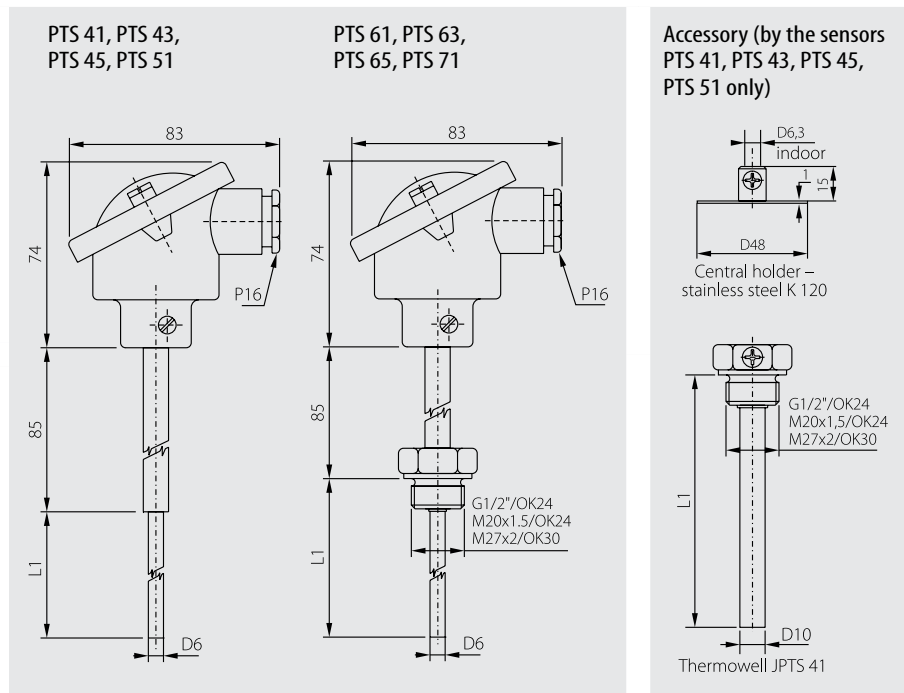

## SENSOR INSTALLATION AND SERVICING

Before connecting the supply lead-in cable, position the sensor in the location of temperature measurement, and screw off the lid of the metal connection head. The lead-in cable is connected to the terminals according to the wiring diagram after pushing it in through the loosened grommet. The recommended wire cross section is 0,35 to 1,5 mm<sup>2</sup>, the outer diameter of the circular cross-section cable can range between 4 and 8 mm. In case the lead-in cable is laid in the vicinity of high voltage conductors or those supplying equipment creating disturbing electromagnetic field (e.g. inductive load equipment), a shielded cable should be used. To insure the ingress protection value of IP 54 the grommet has to be tightened and the lid has to be screwed on after connecting the lead-in cable.

In case of using a stainless steel thermowell or a holder these accessories have first to be installed in the temperature measurement location, then the sensor will be pushed into the holder or eventually to the thermowell bottom, after which the sensor is secured with a screw. (This applies for the PTS 41, PTS 43, PTS 45 and PTS 51 sensors only). The openings for the stainless steel holder installation have to be drilled according to the attached template, on which the opening diameters are illustrated, too. (This applies for the PTS 41, PTS 43, PTS 45 and PTS 51 sensors only). After installing and connecting to the appropriate evaluating electrical equipment the sensor is ready to use. The sensor does not require any special attendance or maintenance. The device can be operated in any working position, but the grommet must not be directed upwards.

## CUSTOMER SPECIFIC MODIFICATIONS

REGARDING TO SENSORS MANUFACTURED IN A STANDARD VERSION THE FOLLOWING PARAMETERS CAN BE MODIFIED:

- changing the sensor length (from 600 mm the pipe D8 x 1 must be used)
- possibility to use a 3-wire or a 4-wire connection
- A class of accuracy for the range -50 to 300 °C
- changing the stem version

## HOW TO ORDER

Platinum temp. sensors for measuring up to 400 °C

	1	2	5	C	C	D	D	0	E	G	G	G	G
output 4–20 mA				0	A								
Pt 100/3850, class B				0	6								
Pt 100/3850, class A				0	7								
Pt 500/3850, class B				0	9								
Pt 500/3850, class A				1	0								
Pt 1000/3850, class B				1	1								
Pt 1000/3850, class A				1	2								
with resistive output						0	0						
0 to 100 °C						0	3						
0 to 150 °C						0	4						
-50 to 50 °C						0	6						
0 to 200 °C						0	7						
0 to 400 °C						0	8						
Thread						Unthreaded		0					
						G 1/2		1					
						M 20 x 1,5		3					
						M 27 x 2		4					
Stem length L1						50 mm		0	0	5	0		
						100 mm		0	1	0	0		
						160 mm		0	1	6	0		
						220 mm		0	2	2	0		
						280 mm		0	2	8	0		
						400 mm		0	4	0	0		

Thermowell – Stainless steel, JPTS 41 (only for PTS 41, PTS 43, PTS 45, PTS 51)

	9	0	0	2	B	B	0	1	0	0	G	G	G	G
Thread														
Thermowell length L1														

Central holder – Stainless steel, K 120 (only for PTS 41, PTS 43, PTS 45, PTS 51)

	9	0	0	0	0	0	0	1	0	0	0	0	0	0
--	---	---	---	---	---	---	---	---	---	---	---	---	---	---

WHEN ORDERING GOODS, THE FOLLOWING DATA ARE REQUIRED:

Required data	Example 1	Required data	Example 2
Product type	PTS 41	Product type	PTS 71
Stem length	220 mm	Stem length	160 mm
Temperature range	–	Temperature range	0 to 100 °C
Acc. – thermowell (length, thread)	Thermowell JPTS 41 (220 mm, G 1/2")	Thread	M 20 x 1,5
– central holder	NO		

The accuracy class is the B class if not stated otherwise.

## DELIVERY

The sensors are packed in pasteboard boxes in accordance with the ordered quantity.

In addition, the following accessories and documents may be provided together with the product:

- the thermowell, the central holder (for PTS 41, PTS 43, PTS 45 and PTS 51 sensors only)
- calibration sheet
- the EU certificate of conformity for PTS 51 and PTS 71.