

DESCRIPTION AND APPLICATION

These paired temperature sensors are used as component parts of the electrical heat quantity meters. They meet the requirements of the IEC 751 and EN 1434 standards and they carry the Certificate EU of type approval identification TCM 321/07-4530. The sensors are produced in accordance with the Council Directive 2004/22/EEC relating to measure devices that was implemented to the legal system of the Czech Republic by the government regulation no. 464/2005 Col.

The sensors are produced with the temperature sensing elements Pt 100, Pt 500 and Pt 1000 and they consist of a case in which the resistant-type sensing element and the metal connection head with the terminal board are fixed. The sensor cases are made of the stainless steel EN X5CrNi18-10 (DIN 1.4301) and have the diameter 6 mm (TP 16) or 3,6 mm (TP 16A). The two-wire or the four-wire connection may be connected to the sensor (the internal sensor connection uses two wires). The metal connection head is made of a aluminium alloy. Optionally, thermowells JTP 16 or JTP 16A made of the stainless steel EN X5CrNi18-10 (DIN 1.4301) can be delivered.

The sensors are designed to be operated in a chemically non-aggressive environment. The standard operating temperature range 0 to 180 °C and 0 to 150 °C.



SPECIFICATIONS

BASIC DATA

Type of sensing element	Pt 100, Pt 500, Pt 1000
Maximum measuring DC current	3 mA (Pt 100); 1,5 mA (Pt 500); 1 mA (Pt 1000)
Measuring range	0 to 180 °C or 0 to 150 °C
$\Delta\Theta_{\min}$	2 °C or 3 °C
$\Delta\Theta_{\max}$	180 °C or 150 °C
Accuracy class of individual sensors	B according to IEC 751
Sensor connection	according to the wiring diagram
Maximum overpressure of the thermowell	6,3 MPa

OTHER PARAMETERS:

Length of the case	TP 16: 105, 140, 230 mm; TP 16A: 97, 133 mm
Diameter of the case	TP 16: 6 mm \pm 0,1 mm; TP 16A: 3,6 mm \pm 0,005 mm
Material of the case and of the thermowell	stainless steel EN X5CrNi18-10 (DIN 1.4301)
Type of the connection head	LIMATHERM MA
Material of the connection head	aluminium alloy
Temperature stability of the connection head	-25 to 100 °C
Internal wiring resistance	TP 16: 0,013 Ω / 105 mm 0,017 Ω / 140 mm 0,027 Ω / 230 mm TP 16A: 0,03 Ω / 97 mm 0,04 Ω / 133 mm
Recommended wire cross section	0,35 to 1,5 mm ²
Ingress protection	IP 54 according to EN 60 529
Insulation resistance	> 100 M Ω at 100 V DC, 15 to 35 °C, humidity < 85 %
Time response	TP 16: $\tau_{0,5}$ < 5 s (in streaming water at 0,4 m.s ⁻¹) TP 16A: $\tau_{0,5}$ < 3 s (in streaming water at 0,4 m.s ⁻¹)
Thermowell types	JTP 16, \varnothing 8 mm; JTP 16A, \varnothing 6 mm
Lengths of thermowells	105, 140, 230 mm (TP 16); 88, 124 mm (TP 16A)
Thermowell thread	G 1/2", M 20 x 1,5

WIRING DIAGRAM

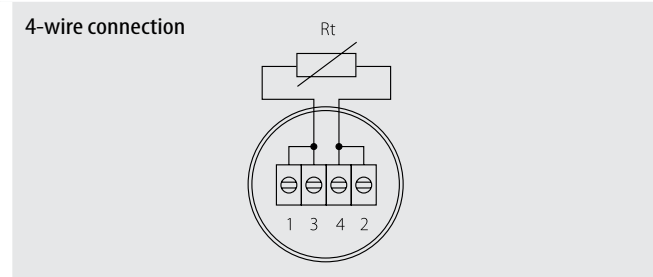
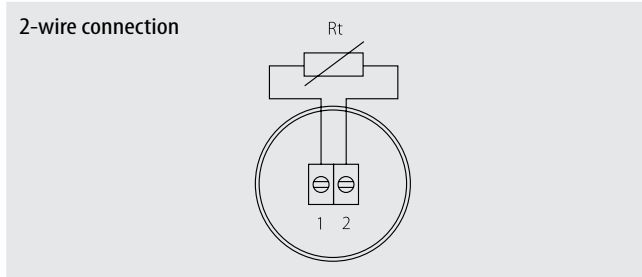

DIMENSIONAL DRAFT

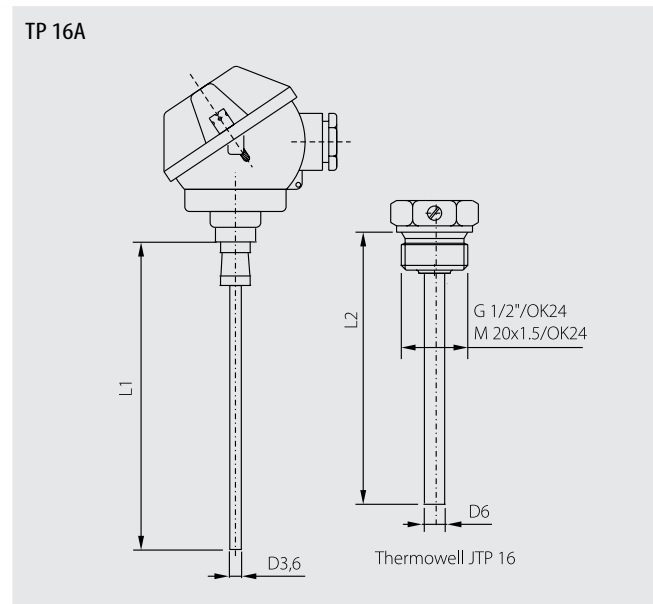
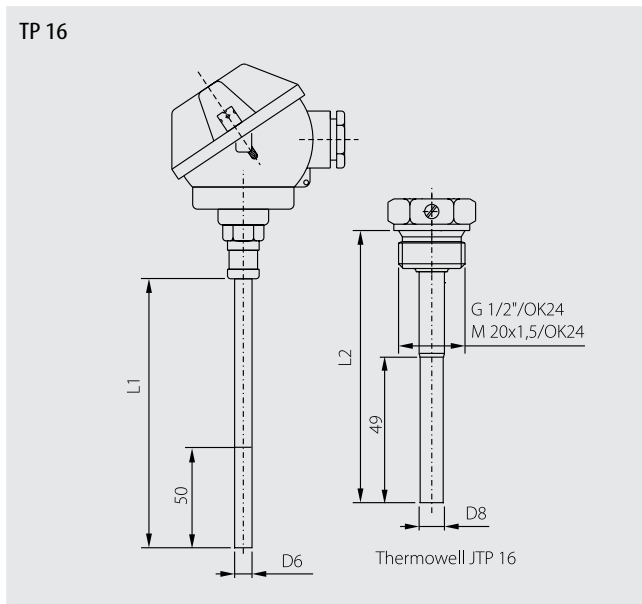

L1 Case length for TP 16	L2 thermowell length for JTP 16
105	105
140	140
230	230

L1 Case length for TP 16A	L2 thermowell length for JTP 16A
97	88
133	124

SENSOR INSTALLATION AND SERVICING

As a rule, the sensors are fitted with thermowells and installed in tubing in a skew position in an angle of 45° counter to the streaming of the media the temperature of which is to be measured. Before installing these paired temperature sensors place first the thermowells in locations where the temperature will be measured, and after that push in the sensors as far as the thermowell bottom. Secure the sensor by a screw located in the thermowell. The screw must be tightened to the endstop.

Before connecting the lead-in cable screw off the lid of the metal connection head. To secure the IP 54 ingress protection the cable grommet has to be tightened and the lid has to be screwed on after connecting the lead-in cable.

To prevent unauthorized manipulation the sensors are provided with sealing openings. The installation sealing wire has first to be pushed through the opening in the connection head, and then through the plumb opening in the thermowell. Then it has to be sealed not to allow to pull out the sensor out of the thermowell.

In the last step the individual sensors are connected to the heat quantity meter.

Caution: Before installation check the identity of the paired sensors by means of the code quoted in the sensor's name plate (the numbers within one pair must be identical). Consult the producer in case the serial numbers are not identical.

CUSTOMER SPECIFIC MODIFICATIONS

REGARDING TO SENSORS MANUFACTURED IN A STANDARD VERSION THE FOLLOWING PARAMETERS CAN BE MODIFIED:

- changing the thermowell thread

HOW TO ORDER

Paired temperature sensors TP 16

		3	1	6	B	B	C	D	E	X	X	X	0	0	0	
Type	TP 16	0	0													
	TP 16A	0	A													
Type of sensing element	Pt 100			1												
	Pt 500			2												
	Pt 1000			3												
Class	$\Delta\Theta_{\min} = 3\text{ }^{\circ}\text{C}$		3													
	$\Delta\Theta_{\min} = 2\text{ }^{\circ}\text{C}$		4													
Connection	2-wire		1													
	4-wire		2													
Case length L1	TP 16		105 mm		1		0		5							
	Case length		140 mm		1		4		0							
	L1		230 mm		2		3		0							

Thermowell for paired temp. sensors JTP 16

		9	0	0	4	B	B	0	2	0	0	E	E	E	E	X	
Thread	G 1/2"	0	1														
	M 20 x 1,5	0	3														
TP 16 Thermowell length L2	TP 16		105 mm		0		1		0		5						
	Thermowell		140 mm		0		1		4		0						
	length L2		230 mm		0		2		3		0						

WHEN ORDERING GOODS, THE FOLLOWING DATA ARE REQUIRED:

Required data	Example
Product type	TP 16
Sensing element type	Pt 500
Connection	2-wire
L1 stem length	140 mm
Thermowell / thread / L2 length	Thermowell JTP 16 / G 1/2" / 140 mm

If not stated otherwise, the accuracy class is the $\Delta\Theta_{\min} = 3\text{ }^{\circ}\text{C}$.

DELIVERY

The sensors are packed by 1 pair in a box marked by label.

In addition, the following accessories may be provided together with the product: – 2 pcs thermowells JTP 16
 – 2 pcs sealing rings.