

DESCRIPTION AND APPLICATION

These temperature switches with display are designed for using as two-state controllers (ON/OFF type control). They compare the temperature set-point with the actual temperature value and enable switching the galvanically separated (electrically insulated) contacts of a connected relay when the set temperature is reached. The switches consist of a plastic box carrying control buttons, display, signalling diodes, terminals for connection the temperature sensing element and power supply and terminal board for connection the output relay contacts. The plastic box is made of ABS material, terminal board ingress protection meets the requirements of IP 20 according to EN 60 529 standard.

Supply voltage of the switches is 7 to 36 V DC or 230 V AC (by the type). Two temperature sensing elements on the base of Pt (Pt 1000/3850) or on the base of Ni (Ni 1000/6180) can be connected to the switches. The display indicates the present value of the measuring temperature during measure process. Setting of individual parameters is executed by two control buttons. The switch can be used in 5 different modes:

- Mode no. 1: the switch operates as a single controller which switches the first relay by the set temperature interval and the second relay is switched at the exceeding set emergency temperature (only one sensing element is used)
- Mode no. 2: the switch operates as a single controller which switches each relay by the set temperature interval (only one sensing element is used)
- Mode no. 3: the switch operates as a double controller, it means that each relay is controlled by the temperature of one sensing element
- Mode no. 4: the switch operates as a differential controller which switches on the base of temperature difference of two sensing elements (analogous to mode no. 1)
- Mode no. 5: the switch operates as a differential controller which switches on the base of temperature difference of two sensing elements (analogous to mode no. 2)

The switches are intended for assembly to the DIN slat. The temperature range of the switch applications depends on used temperature sensing element type (for example for the sensor in the TG8 case the range is -30 to 200 °C). Maximum operating temperature range of the switch is -50 to 250 °C. The switches are intended for operating in a chemically non-aggressive environment.



SPECIFICATIONS

Typ spínače	TSZ2-24	TSZ2H-24	TSZ2-230	TSZ2H-230
Relay	relay 1	relay 1, relay 2	relay 1	relay 1, relay 2
Type of sensing element	Pt 1000/3850 or Ni 1000/6180			
Maximum temperature operating range	-50 to 250 °C			
Power supply	7 – 36 V DC, V AC	7 – 36 V DC, V AC	230 V AC	230 V AC
Maximum switched voltage	250 V AC / 6 A			
Maximum error of the switch*	± (0,2 % from the value + 2 dig)			
Resolution	0,1 °C			
Setting range	-50 to 250 °C, step 0,1 °C			
Display	4 digits – red LED, high of the digits 10 mm			
Brightness of the display setting	4 levels			
Updating of the display	< 0,2 s			
Type of terminal board	terminal board ARK210, wire cross section 0,35 to 1,5 mm ²			
Material of the case	ABS, self-extinguishing, meeting the UL94-V0 standard			
Case dimensions (V x Š x H)	90 x 67 x 65 mm			
Ingress protection	IP 20 according to EN 60 529			
Working conditions	ambient temperature: -5 to 60 °C relative humidity: max 85 % (at the ambient temperature 25 °C) atmospheric pressure: 87 to 107 kPa			
Mass	0,15 kg (without sens. el.)	0,15 kg (without sens. el.)	0,25 kg (without sens. el.)	0,25 kg (without sens. el.)

*error of the sensing element is not incorporated

SWITCH INSTALLATION AND SERVICING

An integral part of the switch is a clamp enabling to fix it on DIN slat. After fixing the unit the relevant supply lead-in cables (terminals 7, 8 – 24 V AC/DC, terminals 15, 16 – 230 V AC), the temperature sensors (terminals 1, 3 – sensing element 1; terminals 2, 3 – sensing element 2) and the cable for the relay output signal (9, 10, 11 – relay 1; 12, 13, 14 – relay 2) are connected to the terminals according to the wiring diagram. The recommended wire cross-section is 0,35 to 1,5 mm². In case the lead-in cable is laid in the vicinity of high voltage conductors or those supplying equipment creating disturbing electromagnetic field (e.g. inductive load equipment), a shielded cable should be used. The shielding of the lead-in cable of the temperature sensor is connected to the terminal no. 3.

WIRING DIAGRAM

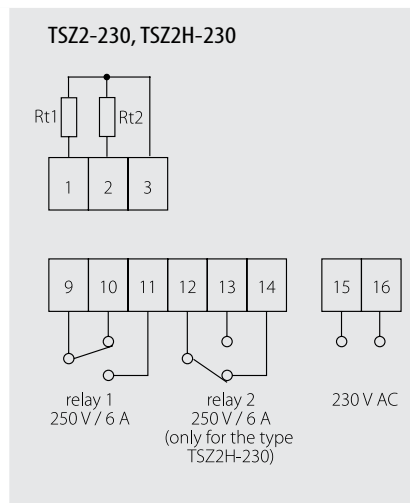
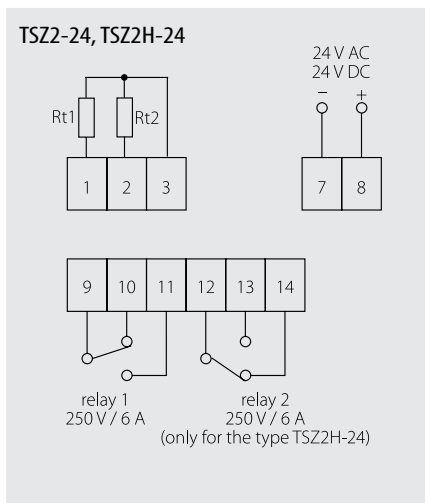

DIMENSIONAL DRAFT

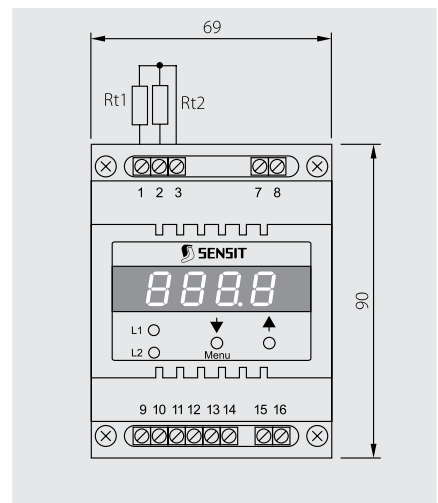

HOW TO ORDER

Temperature switches TSZ2 a TSZ2H	5	A	A	B	0	0	0	0	0	0	0	0	0	0	0	0
Type	TSZ2	5	7													
	TSZ2H	5	8													
Power supply	230 V AC			0												
	24 V DC			3												

WHEN ORDERING GOODS, THE FOLLOWING DATA ARE REQUIRED:

Required data	Example
Product type	TSZ2H-24
Input sensing element	Pt 1000
Sensor type	specification of the sensor
Power supply	24 V AC
Power supply unit	NZ 24V AC

DELIVERY

The sensors are packed in the box by 1 piece.

In addition, the following accessories and documents may be provided together with the product:

- temperature sensor with sensing element Pt 1000 or Ni 1000/6180 (various versions)
- a calibration sheet
- the EU certificate of conformity.