

DESCRIPTION AND APPLICATION

The sensors of the serie SD 12x are intelligent microprocessor-controlled temperature sensors. They were developed in cooperation with the company MIKROKLIMA. They consist of a sensing element in a stainless steel (class EN X5CrNi18-10, DIN 1.4301) stem and of printed circuit boards encased in a plastic connection head which is provided with a cable outlet bushing. The sensors meet the IP65 ingress protection requirements according to the EN 60 529 standard. The standard temperature range in which the sensors are allowed to be utilised is -40 to 150 °C. They are available in three basic variants:

- SD 120** – with a simple ASCII communication protocol consistent with ADAM 4000 modules by ADVANTECH company. Thus, standard drivers for ADAM modules can be used in various control programmes. For easier operation, a green LED indicates power supply and a red LED indicates that the module is communicating. The SD 1x0 module is provided by the INIT shorting jumper on its printed circuit board. If it is shorted when power is switched on, the module communicates on 00 address with 9600 Bd transfer speed without checksum.
- SD 121** – the command structure complies with the ARION communication protocol, which is used in control systems by Amit company.
- SD 122** – the command structure complies with the ModBus comm. protocol.

These sensors are intended for contact measurements of liquid or gaseous substances. They are available with a plastic centric holder for temperature measuring in air-conditioning shafts or with a thermowell for measuring in tubing. The sensors are to be operated in chemically non-aggressive environment.

Communication inputs are protected to overvoltage. In case the module is placed as terminal on the line, a terminating resistor can be attached to the wiring by shorting the contacts (the switch SW next to the terminal for communication lines connection).

All settings are stored in EEPROM memory. The electronic module is equipped with the WATCHDOG circuit, which safeguards proper program functioning in the microprocessor..



SPECIFICATIONS

Sensor type	SD 120	SD 121	SD 122
Power supply	10 to 35 V DC (unstabilized) 14 to 24 V AC		
Power consumption	300 mW		
Measuring range	-40 to 150 °C		
Standard stem lengths	70, 120, 180, 240 mm		
Communication properties	communication via RS 485, maximum segment length is 1200 m, asynchronous transfer		
	transfer speeds 1200, 2400, 4800, 9600, 19200 Bd	transfer speeds 9600, 19200, 38400, 57600 Bd – DIP switch	preset transfer speed 9600 Bd optional transfer speeds 1200, 2400, 4800, 19200, 57600, 115200 Bd – DIP switch
	256 modules / 1 serial port	63 modules / 1 serial port	247 modules / 1 serial port
	protocol consistent with ADAM modules	protocol ARION	protocol ModBus 1 stop bit, without parity
Accuracy of electronics	0,05 %		
Accuracy of sensing element	± 0,5 °C		
Resolution	0,03125 °C		
Working conditions	ambient temperature: -30 to 70 °C		
	relative humidity: max. 85 % (at the ambient temperature 25 °C) atmospheric pressure: 87 to 107 kPa		
Mass	0,2 kg		

WIRING DIAGRAM

SD 120

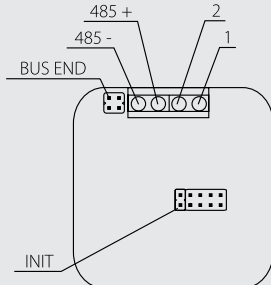
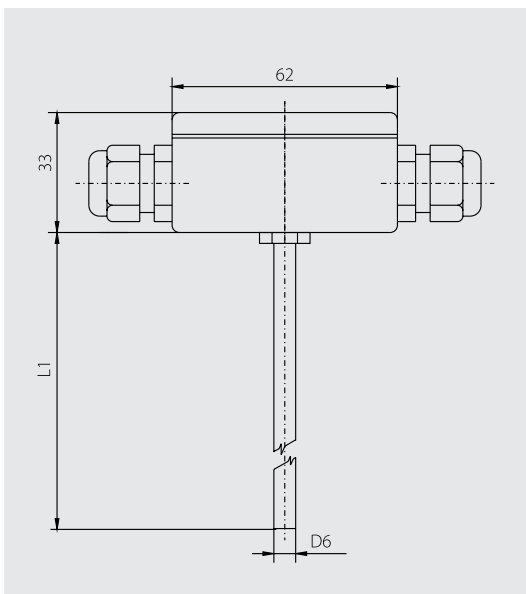
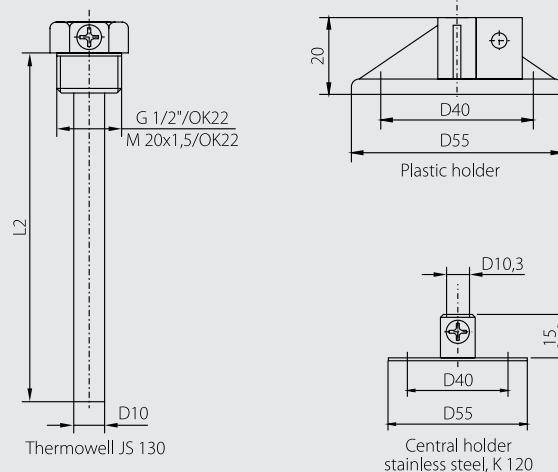

Diagram	Description
1	Power supply
2	Power supply
485 +	+ of RS 485 data bus
485 -	- of RS 485 data bus
INIT	INIT mode initialization
BUS END	Connection for bus ending

DIMENSIONAL DRAFT



Accessory



SENSOR INSTALLATION AND SERVICING

Prior to connecting the supply lead-in cable, unscrew the lid of the plastic connection head. Push the lead-in cable through the loosened grommet and connect it to the terminals according to the wiring diagram. Recommended wire cross-section is 0,35 - 1,5 mm², the outer diameter of the circular cross-section cable can range between 4 and 8 mm.

In case the lead-in cable is laid in the vicinity of high voltage conductors or those supplying equipment creating disturbing electromagnetic field (e.g. inductive load equipment), a shielded cable should be used.

To insure the ingress protection value of IP 65 the grommet has to be tightened and the lid has to be screwed on after connecting the lead-in cable.

The openings for the plastic holder installation should be drilled according to the dimensional draft, where their diameters and distances from center to center are specified.

After installing and connecting the sensor to the appropriate evaluating electrical equipment the sensor is ready to use. The sensor does not require any special attendance or maintenance. The device can be operated in any working position, but the grommet must not be directed upwards.

CUSTOMER SPECIFIC MODIFICATIONS

REGARDING TO SENSORS MANUFACTURED IN A STANDARD VERSION THE FOLLOWING PARAMETERS CAN BE MODIFIED:

- sensor length can be up to 6 m (if longer than 1 m, a D 6x1 pipe is used)
- stem modification – variants with a thread etc.
- stainless steel material change, for example DIN 4.4571
- size of thermowell thread

